



APEX DYNAMICS, INC.

AD / ADR / ADS Series

Planetary Gearboxes
High Precision
High Speed



Stainless

AD / ADR / ADS Series

Characteristic Highlights

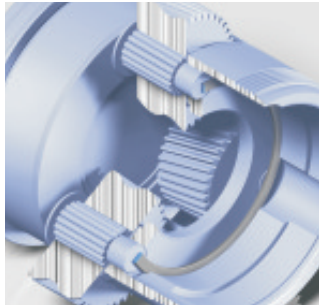

Planet gears rotate on **solid uncaged needle roller bearings** for increased stiffness and the maximum number of contact points. Hardened thrust washers allow the precise control of clearances in order to eliminate backlash.

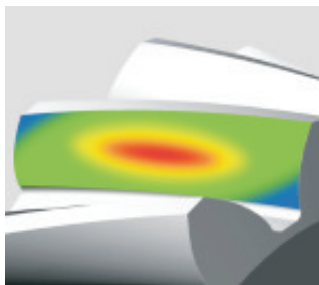

Industry-leading gear performance is attained with our **HeliTopo technology**. **Ease off of the tooth profile and lead crowning** optimizes the gear mesh under load and achieves maximum tooth surface contact.

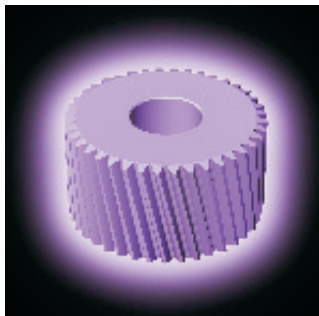

Our **In-house plasma nitriding** treatment process allows the hardness of the gear flanks to reach over 900Hv for superior wear resistance and still maintain a core hardness of 30HRC for toughness and resistance to shock loading.

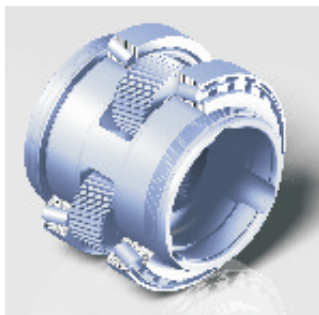

One-piece carrier and output housing ensure 100% concentricity and alignment of all the rotating components. One-piece construction increases strength, rigidity and system reliability.



Helical gear design. Helical gearing increases the tooth to tooth contact ratio by as much as 33%. Benefits include increased torque capacity, ultimate smoothness, lower backlash and decreased noise. The helix angle is carefully chosen to gain these advantages while not producing excessive axial forces.

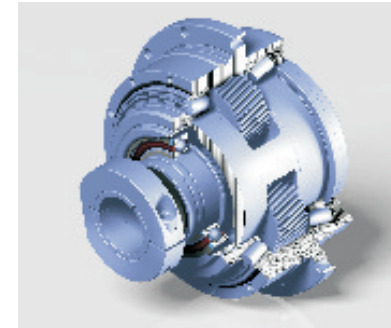

Patented planet carrier design mounts the sun gear bearing directly into the planet carrier in order to eliminate misalignment. This exclusive design offers great advantages in decreased noise, vibration and transmission errors and losses.

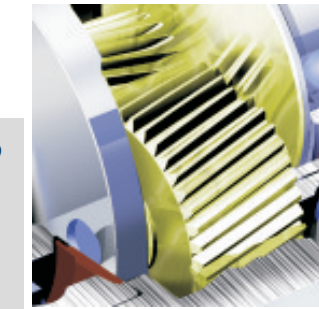

Lubrication by synthetic Nyogel 792D grease for smooth operation over the whole service life. Sealed to **IP65** standard for ingress protection and can be mounted in any orientation.



Triple-split collet and dynamically balanced set collar clamping system for efficient power transmission. Perfect concentricity from one-piece sun gear reduces backlash and allows higher input speeds.

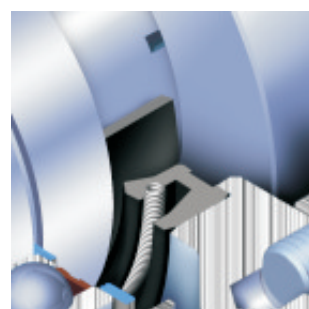
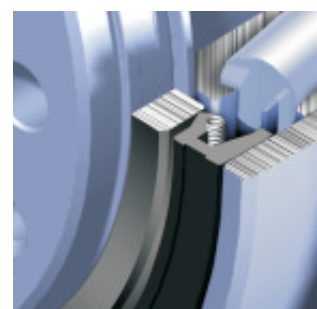
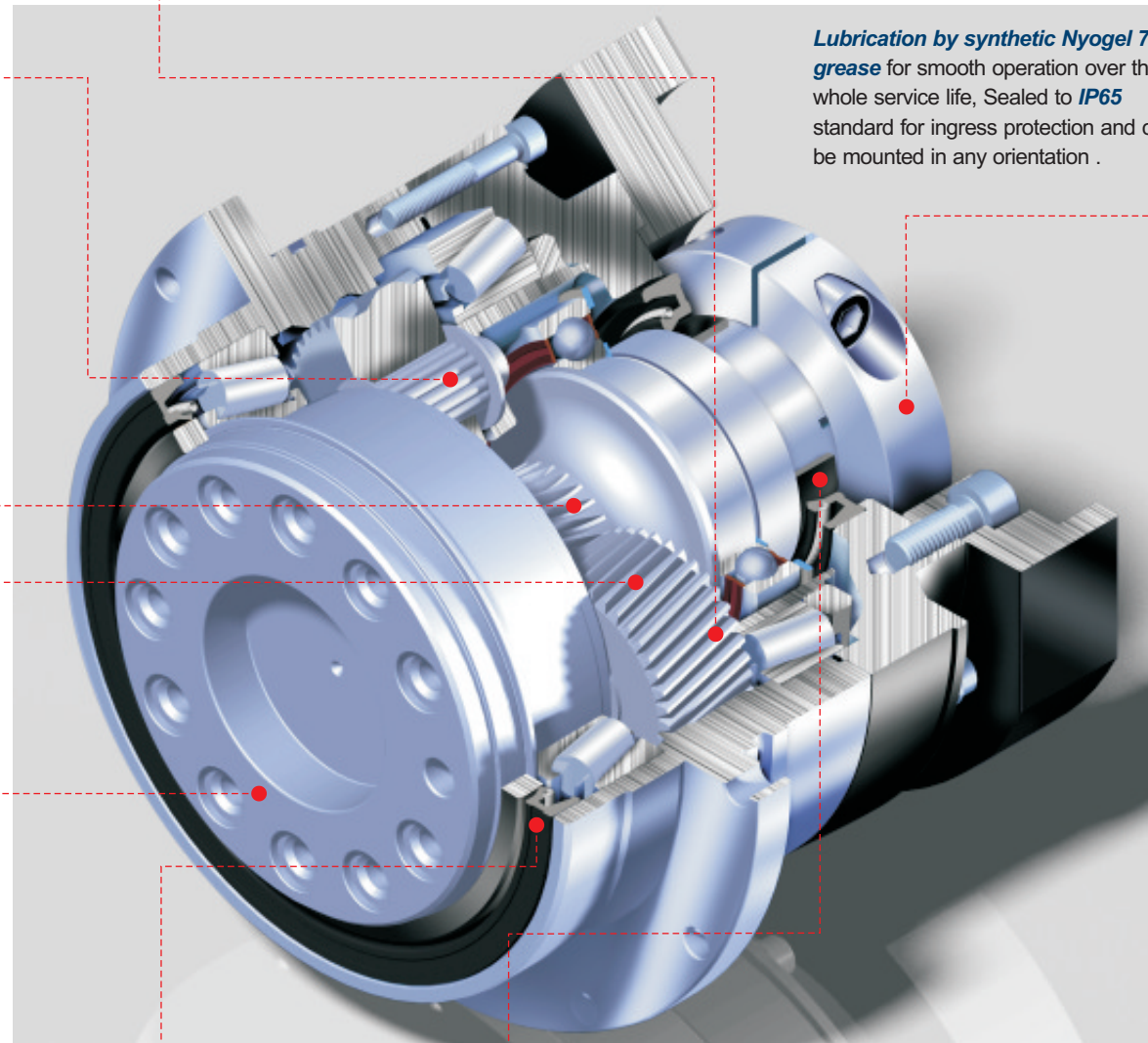

Patented sealing system featuring a TiCN coated shaft surface that eliminates leakage and increases service life to over 30,000 hours. The high tech coating, with a surface quality of $0.2 \mu\text{m}$ and hardness of 3700 Hv. Interfaces with our proprietary seal, decreasing wear and running temperature.

ADR version with 90° input via spiral bevel gear. Featuring an extremely short, rigid housing with full compatibility to any motor.

ADR Series

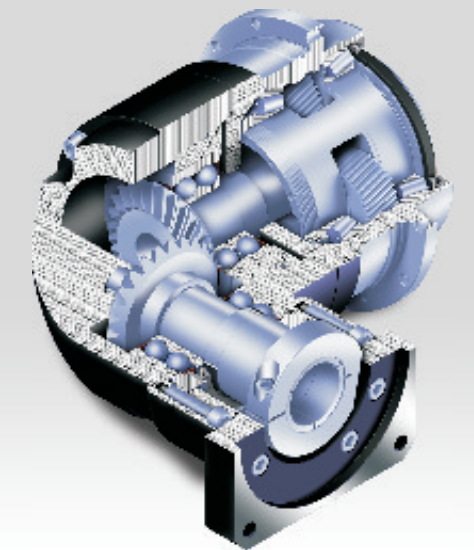

ADS Series

ADS version specially designed input shaft with key and threaded hole. Easy to drive via timing belt pulley or coupling. For increasing design flexibility and space saving for motor mounting. Ideal for highly dynamic cyclic duty or continuous running application.

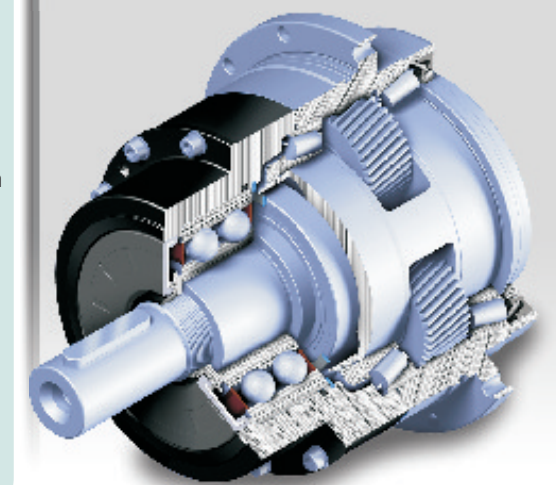

AD Series

Specifications

Gearbox Performance

Model No.	Stage	Ratio ¹	AD047	AD064	AD090	AD110	AD140	AD200	AD255					
Nominal Output Torque T_{2N}	Nm	1	4	19	48	130	270	560	1,100	1,700				
			5	22	60	160	330	650	1,200	2,000				
			7	19	50	140	300	550	1,100	1,800				
			10	14	40	100	230	450	900	1,500				
		2	20	19	48	130	270	560	1,100	1,700				
			25	22	60	160	330	650	1,200	2,000				
			35	19	50	140	300	550	1,100	1,800				
			40	19	48	130	270	560	1,100	1,700				
			50	22	60	160	330	650	1,200	2,000				
	2	70	19	50	140	300	550	1,100	1,800					
		100	14	40	100	230	450	900	1,500					
		16	19	48	130	270	560	1,100	1,700					
		21	22	60	160	330	650	1,200	2,000					
	Emergency Stop Torque T_{2NOT} ²	Nm	1,2	4~100	3 times of Nominal Output Torque									
				Nominal Input Speed n_{1N}	rpm	1,2	4~100	5,000	5,000	4,000	4,000	3,000	3,000	2,000
				Max. Input Speed n_{1B}	rpm	1,2	4~100	10,000	10,000	8,000	8,000	6,000	6,000	4,000
	Micro Backlash P0	arcmin	1	4~10	-	-	≤1	≤1	≤1	≤1	≤1			
			2	20~100	-	-	-	≤3	≤3	≤3	≤3			
Reduced Backlash P1	arcmin	1	4~10	≤3	≤3	≤3	≤3	≤3	≤3	≤3				
		2	20~100	≤5	≤5	≤5	≤5	≤5	≤5	≤5				
Standard Backlash P2	arcmin	1	4~10	≤5	≤5	≤5	≤5	≤5	≤5	≤5				
		2	20~100	≤7	≤7	≤7	≤7	≤7	≤7	≤7				
Torsional Rigidity	Nm/arcmin	1,2	4~100	7	13	31	82	151	440	1,006				
Max. Bending moment M_{2KB} ³	Nm	1,2	4~100	42.5	125	235	430	1,300	3,064	5,900				
Max. Axial Load F_{2B} ³	N	1,2	4~100	1,080	2,110	2,310	4,800	6,200	5,450	10,600				
Service Life	hr	1,2	4~100	30,000*										
Efficiency η	%	1	4~10	≥97%										
		2	20~100	≥94%										
Weight	kg	1	4~10	0.7	1.2	3.0	5.6	11.9	31.6	56.1				
			2	20~100	1.0	1.6	3.7	7.3	15.9	36.9	70.4			
		16~91	1.0	1.4	3.5	6.5	15.5	34.2	67.2					
Operating Temp	°C	1,2	4~100	-10°C~+90°C										
Lubrication		1,2	4~100	synthetic gear grease (NYOGEL 792D)										
Degree of Gearbox Protection		1,2	4~100	IP65										
Mounting Position		1,2	4~100	all directions										
Noise Level ($n_1=3000$ rpm)	dB	1,2	4~100	≤56	≤58	≤60	≤63	≤65	≤67	≤70				

Gearbox Inertia

Model No.	Stage	Ratio ¹	AD047	AD064	AD090	AD110	AD140	AD200	AD255	
Mass Moments of Inertia J_1	kg · cm ²	1	4	0.03	0.14	0.51	2.87	7.54	25.03	58.31
			5	0.03	0.13	0.47	2.71	7.42	23.29	53.27
			7	0.03	0.13	0.45	2.62	7.14	22.48	50.97
			10	0.03	0.13	0.44	2.57	7.03	22.51	50.56
		2	20	0.03	0.03	0.13	0.47	2.71	7.42	23.29
			25	0.03	0.03	0.13	0.47	2.71	7.42	23.29
			35	0.03	0.03	0.13	0.47	2.71	7.42	23.29
			40	0.03	0.03	0.13	0.44	2.57	7.03	22.51
			50	0.03	0.03	0.13	0.44	2.57	7.03	22.51
	2	70	0.03	0.03	0.13	0.44	2.57	7.03	22.51	
		100	0.03	0.03	0.13	0.44	2.57	7.03	22.51	
		16	0.03	0.03	0.13	0.47	2.71	7.42	23.29	
		21	0.03	0.03	0.13	0.47	2.71	7.42	23.29	
	2	31	0.03	0.03	0.13	0.44	2.57	7.03	22.51	
		61	0.03	0.03	0.13	0.44	2.57	7.03	22.51	
		91	0.03	0.03	0.13	0.44	2.57	7.03	22.51	

1. Ratio ($i=N_{in}/N_{out}$)

2. $T_{2B} = 60\%$ of T_{2NOT}

3. Applied to the output shaft center @ 100 rpm

*S1 service life 15,000 hrs

Dimensions (1-stage, Ratio $i=4\sim 10$)

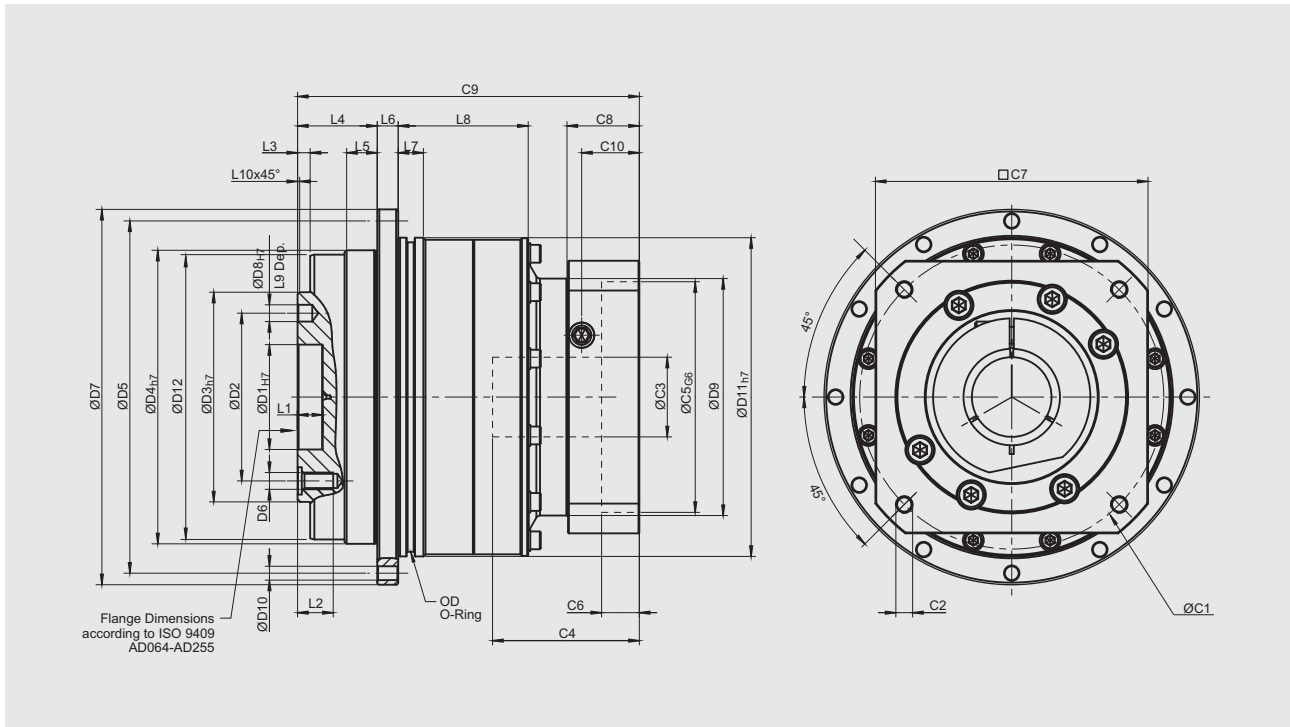

[unit: mm]

Dimension	AD047	AD064	AD090	AD110	AD140	AD200	AD255
D1 ^{H7}	12	20	31.5	40	50	80	100
D2	20	31.5	50	63	80	125	140
D3 ^{h7}	28	40	63	80	100	160	180
D4 ^{h7}	47	64	90	110	140	200	255
D5	67	79	109	135	168	233	280
D6	4 x M3 x 0.5P	7 x M5 x 0.8P	7 x M6 x 1P	11 x M6 x 1P	11 x M8 x 1.25P	11 x M10 x 1.5P	12 x M16 x 2P
D7	72	86	118	145	179	247	300
D8 ^{H7}	3	5	6	6	8	10	12
D9	45.5	55	77	90	113	138	175
D10	8 x 3.4	8 x 4.5	8 x 5.5	8 x 5.5	12 x 6.6	12 x 9	16 x 13.5
D11 ^{h7}	60	70	95	120	152	212	255
D12	46.2	63.2	89.2	109.2	139.2	199.2	254.2
L1	4	8	12	12	12	16	20
L2	6.5	8	13.5	13.5	17	22.5	30.5
L3	3	3	6	6	6	8	12
L4	19.5	19.5	30	29	38	50	66
L5	7	7	10	10	14.6	15	20
L6	4	4	7	8	10	12	18
L7	5	7.7	8	10	12	15	20
L8	18.5	28.5	27	37	62	69.5	82
L9	4	6	7	7	7	10	10
L10	0.5	0.5	1	1	1	1	1
C1 ⁴	46	70	100	130	165	215	235
C2 ⁴	M4 x 0.7P	M5 x 0.8P	M6 x 1P	M8 x 1.25P	M10 x 1.5P	M12 x 1.75P	M12 x 1.75P
C3 ⁴	≤11	* ≤14 / ≤16	≤19 / ≤24	≤32	≤38	≤48	≤55
C4 ⁴	30	34	40	50	60	85	116
C5 ³ _{G6}	30	50	80	110	130	180	200
C6 ³	3.5	8	4	5	6	6	6
C7 ⁴	48	60	90	115	142	190	220
C8 ⁴	19.5	19	17	19.5	22.5	29	63
C9 ⁴	70	82.5	99.5	121.5	151	199.5	256.5
C10 ⁴	13.25	13.5	10.75	13	15	20.75	53.5
OD	56 x 2	66 x 2	90 x 3	110 x 3	145 x 3	200 x 5	238 x 5

4. C1~C10 are motor specific dimensions (metric std shown). Refer to apexdyna.com and design tool to view your specific motor mounting system.
*AD064 ratio 5, 10 offers C3 ≤ 16 option.

AD Series

Dimensions (2-stage, Ratio $i=20\sim 100$)

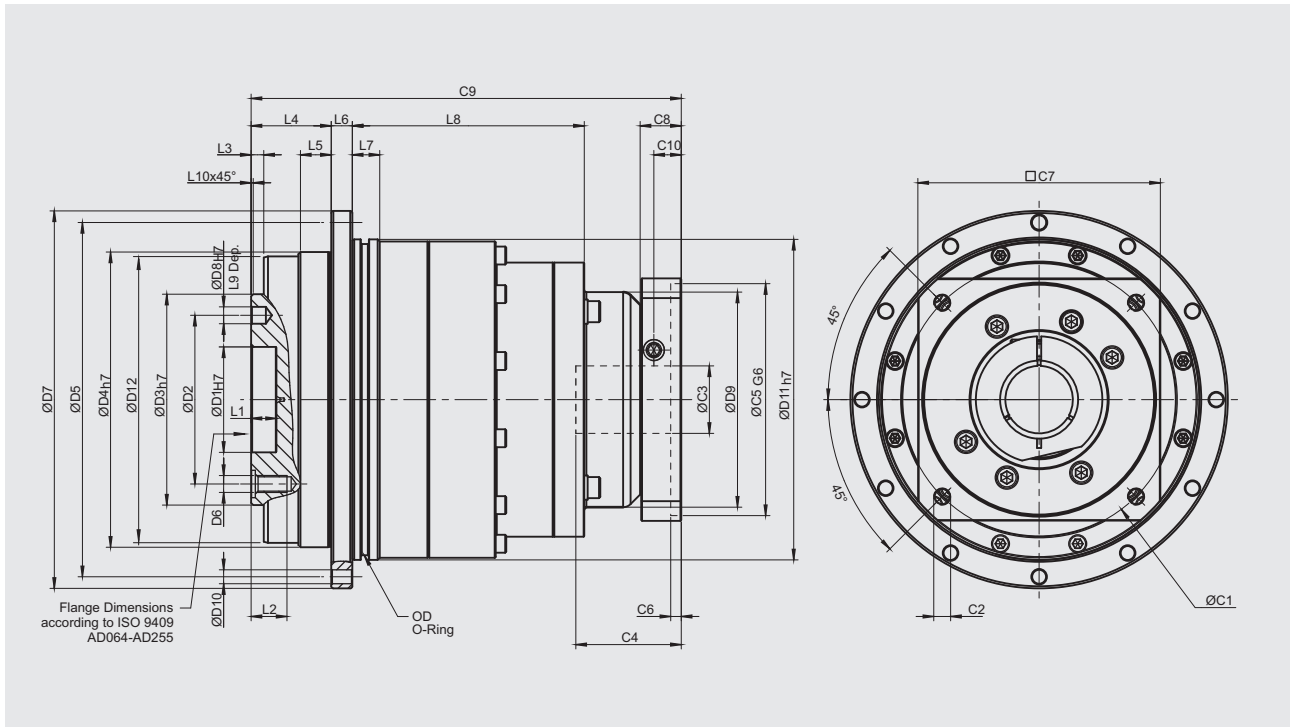

[unit: mm]

Dimension	AD047	AD064	AD090	AD110	AD140	AD200	AD255
D1 _{H7}	12	20	31.5	40	50	80	100
D2	20	31.5	50	63	80	125	140
D3 _{H7}	28	40	63	80	100	160	180
D4 _{H7}	47	64	90	110	140	200	255
D5	67	79	109	135	168	233	280
D6	4 x M3 x 0.5P	7 x M5 x 0.8P	7 x M6 x 1P	11 x M6 x 1P	11 x M8 x 1.25P	11 x M10 x 1.5P	12 x M16 x 2P
D7	72	86	118	145	179	247	300
D8 _{H7}	3	5	6	6	8	10	12
D9	45.5	45.5	53.4	77	102	125	160
D10	8 x 3.4	8 x 4.5	8 x 5.5	8 x 5.5	12 x 6.6	12 x 9	16 x 13.5
D11 _{H7}	60	70	95	120	152	212	255
D12	46.2	63.2	89.2	109.2	139.2	199.2	254.2
L1	4	8	12	12	12	16	20
L2	6.5	8	13.5	13.5	17	22.5	30.5
L3	3	3	6	6	6	8	12
L4	19.5	19.5	30	29	38	50	66
L5	7	7	10	10	14.6	15	20
L6	4	4	7	8	10	12	18
L7	5	7.7	8	10	12	15	20
L8	54.5	65	60	87.5	110	132.5	148
L9	4	6	7	7	7	10	10
L10	0.5	0.5	1	1	1	1	1
C1 ⁵	46	46	70	100	130	165	215
C2 ⁵	M4 x 0.7P	M4 x 0.7P	M5 x 0.8P	M6 x 1P	M8 x 1.25P	M10 x 1.5P	M12 x 1.75P
C3 ⁵	≤11	* ≤11 / ≤12	* ≤14 / ≤15.875 / ≤16	≤19 / ≤24	≤32	≤38	≤48
C4 ⁵	30	30	34	40	50	60	85
C5 ⁵ _{G6}	30	30	50	80	110	130	180
C6 ⁵	3.5	3.5	8	4	5	6	6
C7 ⁵	48	48	60	90	115	142	190
C8 ⁵	19.5	19.5	19	17	19.5	22.5	29
C9 ⁵	97.5	108	134	160	204	248	311.5
C10 ⁵	13.25	13.25	13.5	10.75	13	15	20.75
OD	56 x 2	66 x 2	90 x 3	110 x 3	145 x 3	200 x 5	238 x 5

5. C1-C10 are motor specific dimensions (metric std shown). Refer to apexdyna.com and design tool to view your specific motor mounting system.
 * AD064 ratio 20-50 offers C3 ≤ 12 option. * AD090 ratio 20-50 offers C3 ≤ 15.875 / ≤ 16 option.

AD Series

Dimensions (2-stage, Ratio $i=16,21,31,61,91$)

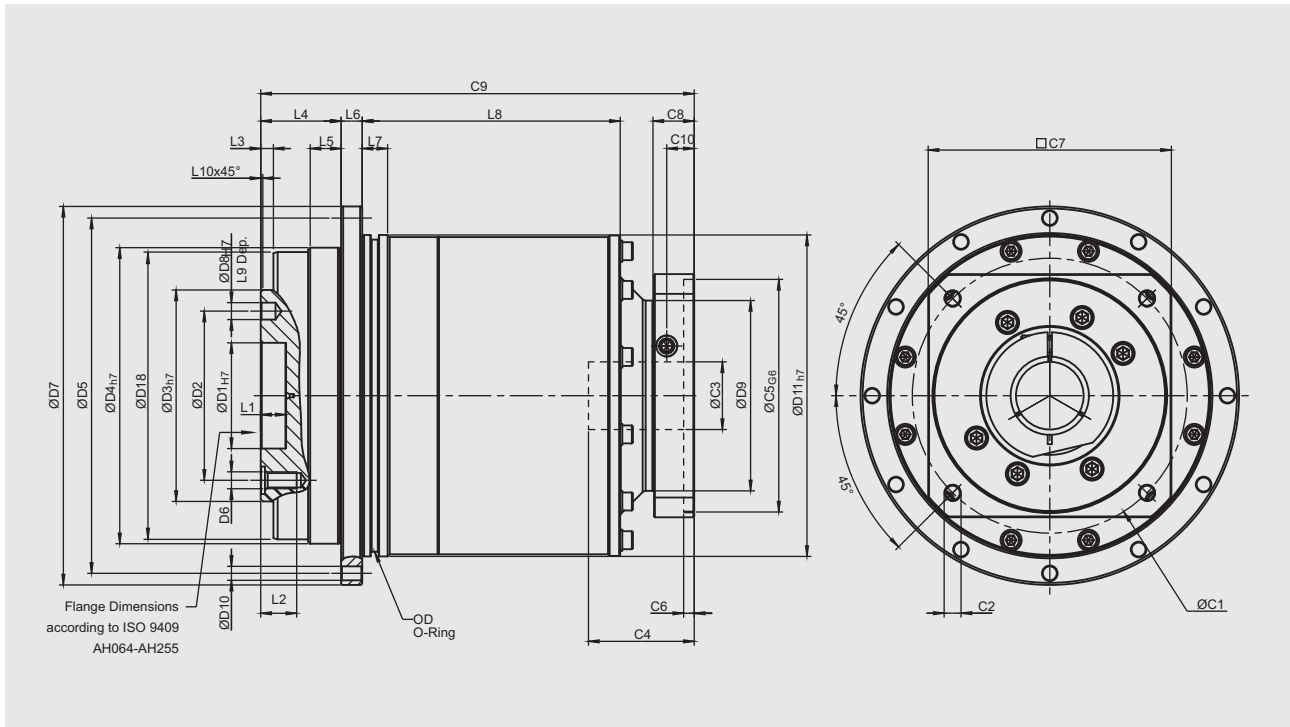

[unit: mm]

Dimension	AD047	AD064	AD090	AD110	AD140	AD200	AD255
D1 _{H7}	12	20	31.5	40	50	80	100
D2	20	31.5	50	63	80	125	140
D3 _{h7}	28	40	63	80	100	160	180
D4 _{h7}	47	64	90	110	140	200	255
D5	67	79	109	135	168	233	280
D6	4 x M3 x 0.5P	7 x M5 x 0.8P	7 x M6 x 1P	11 x M6 x 1P	11 x M8 x 1.25P	11 x M10 x 1.5P	12 x M16 x 2P
D7	72	86	118	145	179	247	300
D8 _{H7}	3	5	6	6	8	10	12
D9	45.5	45.5	55	77	90	113	138
D10	8 x 3.4	8 x 4.5	8 x 5.5	8 x 5.5	12 x 6.6	12 x 9	16 x 13.5
D11 _{h7}	60	70	95	120	152	212	255
D18	46.2	63.2	89.2	109.2	139.2	199.2	254.2
L1	4	8	12	12	12	16	20
L2	6.5	8	13.5	13.5	17	22.5	30.5
L3	3	3	6	6	6	8	12
L4	19.5	19.5	30	29	38	50	66
L5	7	7	10	10	14.6	15	20
L6	4	4	7	8	10	12	18
L7	5	7.7	8	10	12	15	20
L8	52.5	28.5	32	37	122	79.5	82
L9	4	6	7	7	7	10	10
L10	0.5	0.5	1	1	1	1	1
C1 ⁵	46	46	70	100	130	165	215
C2 ⁵	M4 x 0.7P	M4 x 0.7P	M5 x 0.8P	M6 x 1P	M8 x 1.25P	M10 x 1.5P	M12 x 1.75P
C3 ⁵	≤11	* ≤11 / ≤12	* ≤14 / ≤15.875 / ≤16	≤19 / ≤24	≤32	≤38	≤48
C4 ⁵	30	30	34	40	50	60	85
C5 ⁵ _{G6}	30	30	50	80	110	130	180
C6 ⁵	3.5	3.5	8	4	5	6	6
C7 ⁵	48	48	60	90	115	142	190
C8 ⁵	19.5	19.5	19	17	19.5	22.5	29
C9 ⁵	100	106	130.5	149	205	247.5	323
C10 ⁵	13.25	13.25	13.5	10.75	13	15	20.75
OD	56 x 2	66 x 2	90 x 3	110 x 3	145 x 3	200 x 5	238 x 5

6. C1~C10 are motor specific dimensions (metric std shown). Refer to apexdyna.com and design tool to view your specific motor mounting system.
 *AD064 ratio 16~31 provides C3≤12 option. *AD090 ratio 16~31 provides C3≤15.875 / ≤16 option.

ADR Series

Specifications

Gearbox Performance

Model No.	Stage	Ratio ¹	ADR047	ADR064	ADR090	ADR110	ADR140	ADR200	ADR255	
Nominal Output Torque T_{2N}	1	4	19	48	130	270	560	1,100	1,700	
		5	22	60	160	330	650	1,200	2,000	
		7	19	50	140	300	550	1,100	1,800	
		10	14	40	100	230	450	900	1,500	
		14	-	42	140	300	550	1,100	1,800	
		20	-	40	100	230	450	900	1,500	
	2	20	19	-	-	-	-	-	-	-
		25	22	60	160	330	650	1,200	2,000	
		35	19	50	140	300	550	1,100	1,800	
		40	19	48	130	270	560	1,100	1,700	
		50	22	60	160	330	650	1,200	2,000	
		70	19	50	140	300	550	1,100	1,800	
		100	14	40	100	230	450	900	1,500	
		140	-	-	140	300	550	1,100	1,800	
200	-	-	100	230	450	900	1,500			
Emergency Stop Torque T_{2NOT} ²	Nm	1,2	4~200	3 times of Nominal Output Torque						
Nominal Input Speed n_{1N}	rpm	1,2	4~200	5,000	5,000	4,000	4,000	3,000	3,000	2,000
Max. Input Speed n_{1B}	rpm	1,2	4~200	10,000	10,000	8,000	8,000	6,000	6,000	4,000
Micro Backlash P0	arcmin	1	4~20	-	-	≤2	≤2	≤2	≤2	≤2
		2	25~200	-	-	≤4	≤4	≤4	≤4	≤4
Reduced Backlash P1	arcmin	1	4~20	≤4	≤4	≤4	≤4	≤4	≤4	≤4
		2	25~200	≤7	≤7	≤7	≤7	≤7	≤7	≤7
Standard Backlash P2	arcmin	1	4~20	≤6	≤6	≤6	≤6	≤6	≤6	≤6
		2	25~200	≤9	≤9	≤9	≤9	≤9	≤9	≤9
Torsional Rigidity	Nm/arcmin	1,2	4~200	7	13	31	82	151	440	1,006
Max. Bending moment M_{2KB} ³	Nm	1,2	4~200	42.5	125	235	430	1,300	3,064	5,900
Max. Axial Load F_{2B} ³	N	1,2	4~200	1,080	2,110	2,310	4,800	6,200	5,450	10,600
Service Life	hr	1,2	4~200	30,000*						
Efficiency η	%	1	4~20	≥95%						
		2	25~200	≥92%						
Weight	kg	1	4~20	1.1	2.1	5.9	10.5	21.9	50.9	85.4
		2	25~200	1.4	1.9	4.5	9.8	20.1	45.4	85.9
Operating Temp	°C	1,2	4~200	-10°C~+90°C						
Lubrication		1,2	4~200	synthetic gear grease (NYOGEL 792D)						
Degree of Gearbox Protection		1,2	4~200	IP65						
Mounting Position		1,2	4~200	all directions						
Noise Level ($n_1=3000$ rpm)	dB	1,2	4~200	≤61	≤63	≤65	≤68	≤70	≤72	≤74

Gearbox Inertia

Model No.	Stage	Ratio ¹	ADR047	ADR064	ADR090	ADR110	ADR140	ADR200	ADR255
Mass Moments of Inertia J_1	1	4~10	0.09	0.35	2.25	6.84	23.4	68.9	135.4
		14	-	0.07	1.87	6.25	21.8	65.6	119.8
		20	-	0.07	1.87	6.25	21.8	65.6	119.8
	2	20	0.09	-	-	-	-	-	-
		25~100	0.09	0.09	0.35	2.25	6.84	23.4	68.9
		140~200	-	-	0.31	1.87	6.25	21.8	65.6

1. Ratio ($i=N_{in}/N_{out}$)

2. $T_{2B} = 60\%$ of T_{2NOT}

3. Applied to the output shaft center @ 100 rpm

*S1 service life 15,000 hrs

ADR Series

Dimensions (1-stage, Ratio $i=4\sim 20$)

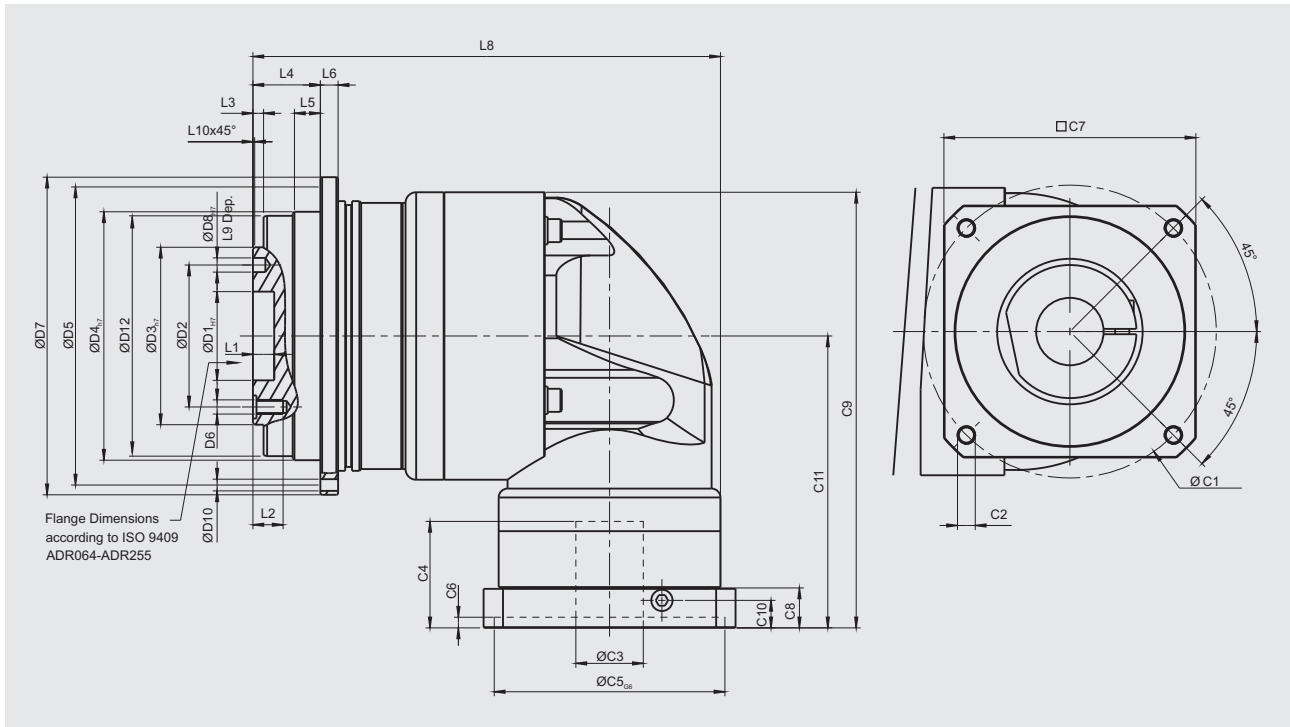

[unit: mm]

Dimension	ADR047	ADR064	ADR090	ADR110	ADR140	ADR200	ADR255
D1 ^{H7}	12	20	31.5	40	50	80	100
D2	20	31.5	50	63	80	125	140
D3 ^{h7}	28	40	63	80	100	160	180
D4 ^{h7}	47	64	90	110	140	200	255
D5	67	79	109	135	168	233	280
D6	4 x M3 x 0.5P	7 x M5 x 0.8P	7 x M6 x 1P	11 x M6 x 1P	11 x M8 x 1.25P	11 x M10 x 1.5P	12 x M16 x 2P
D7	72	86	118	145	179	247	300
D8 ^{H7}	3	5	6	6	8	10	12
D10	8 x 3.4	8 x 4.5	8 x 5.5	8 x 5.5	12 x 6.6	12 x 9	16 x 13.5
D12	46.2	63.2	89.2	109.2	139.2	199.2	254.2
L1	4	8	12	12	12	16	20
L2	6.5	8	13.5	13.5	17	22.5	30.5
L3	3	3	6	6	6	8	12
L4	19.5	19.5	30	29	38	50	66
L5	7	7	10	10	14.6	15	20
L6	4	4	7	8	10	12	18
L8	107.5	126	172.5	201	263.5	334.5	392
L9	4	6	7	7	7	10	10
L10	0.5	0.5	1	1	1	1	1
C1 ⁴	46	70	100	130	165	215	235
C2 ³	M4 x 0.7P	M5 x 0.8P	M6 x 1P	M8 x 1.25P	M10 x 1.5P	M12 x 1.75P	M12 x 1.75P
C3 ³	≤11	≤14 / ≤16	≤19 / ≤24	≤32	≤38	≤48	≤55
C4 ³	30	34	40	50	60	85	116
C5 ¹ _{G6}	30	50	80	110	130	180	200
C6 ³	3.5	8	4	5	6	6	6
C7 ³	48	60	90	115	142	190	220
C8 ³	19.5	19	17	19.5	22.5	29	63
C9 ³	104.25	116.5	159.5	199	245.5	316	398.5
C10 ⁴	13.25	13.5	10.75	13	15	20.75	53.5
C11 ⁴	74	81.5	107.5	134	164.5	213.5	268.5

4. C1~C11 are motor specific dimensions (metric std shown). Refer to apexdyna.com and design tool to view your specific motor mounting system.

ADR Series

Dimensions (2-stage, Ratio $i=25\sim 200$)

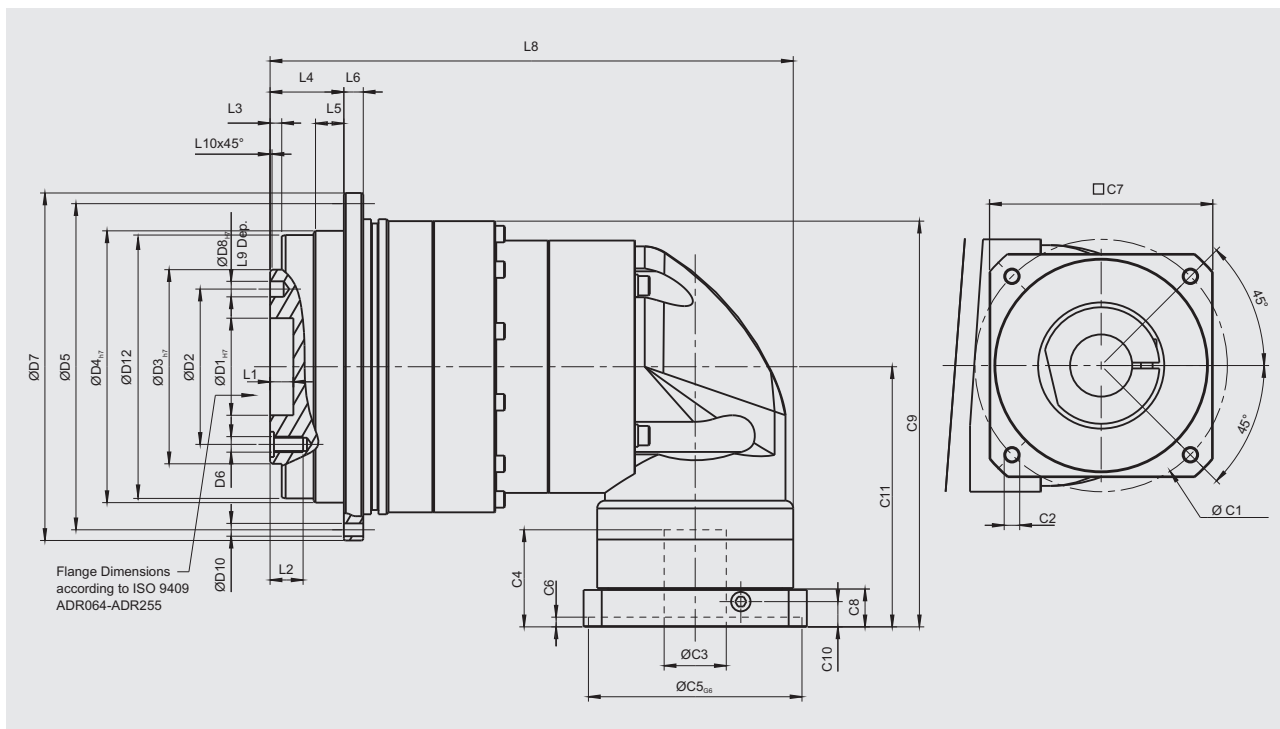

[unit: mm]

Dimension	ADR047	ADR064	ADR090	ADR110	ADR140	ADR200	ADR255
D1 _{H7}	12	20	31.5	40	50	80	100
D2	20	31.5	50	63	80	125	140
D3 _{h7}	28	40	63	80	100	160	180
D4 _{h7}	47	64	90	110	140	200	255
D5	67	79	109	135	168	233	280
D6	4 x M3 x 0.5P	7 x M5 x 0.8P	7 x M6 x 1P	11 x M6 x 1P	11 x M8 x 1.25P	11 x M10 x 1.5P	12 x M16 x 2P
D7	72	86	118	145	179	247	300
D8 _{H7}	3	5	6	6	8	10	12
D10	8 x 3.4	8 x 4.5	8 x 5.5	8 x 5.5	12 x 6.6	12 x 9	16 x 13.5
D12	46.2	63.2	89.2	109.2	139.2	199.2	254.2
L1	4	8	12	12	12	16	20
L2	6.5	8	13.5	13.5	17	22.5	30.5
L3	3	3	6	6	6	8	12
L4	19.5	19.5	30	29	38	50	66
L5	7	7	10	10	14.6	15	20
L6	4	4	7	8	10	12	18
L8	122	132.5	163	217.5	269.5	333.5	403
L9	4	6	7	7	7	10	10
L10	0.5	0.5	1	1	1	1	1
C1 ⁵	46	46	70	100	130	165	215
C2 ⁵	M4 x 0.7P	M4 x 0.7P	M5 x 0.8P	M6 x 1P	M8 x 1.25P	M10 x 1.5P	M12 x 1.75P
C3 ⁵	≤11	≤11 / ≤12	≤14 / ≤15.875 / ≤16	≤19 / ≤24	≤32	≤38	≤48
C4 ⁵	30	30	34	40	50	60	85
C5 ⁵ _{G6}	30	30	50	80	110	130	180
C6 ⁵	3.5	3.5	8	4	5	6	6
C7 ⁵	48	48	60	90	115	142	190
C8 ⁵	19.5	19.5	19	17	19.5	22.5	29
C9 ⁵	103.25	108.25	128.25	166.5	209	269.5	340
C10 ⁵	13.25	13.25	13.5	10.75	13	15	20.75
C11 ⁵	74	74	81.5	107.5	134	164.5	213.5

5. C1-C11 are motor specific dimensions (metric std shown). Refer to Apexdyna.com and Design Tool to view your specific motor mounting system.

ADS Series

Specifications

Gearbox Performance

Model No.	Stage	Ratio ¹	ADS047	ADS064	ADS090	ADS110	ADS140	ADS200	ADS255	
Nominal Output Torque T_{2N}	1	4	19	48	130	270	560	1,100	1,700	
		5	22	60	160	330	650	1,200	2,000	
		7	19	50	140	300	550	1,100	1,800	
		10	14	40	100	230	450	900	1,500	
	2	16	19	48	130	270	560	1,100	1,700	
		21	22	60	160	330	650	1,200	2,000	
		31	19	50	140	300	550	1,100	1,800	
		61	19	50	140	300	550	1,100	1,800	
	91	14	40	100	230	450	900	1,500		
Emergency Stop Torque T_{2NOT} ²	Nm	1,2	4~91	3 times of Nominal Output Torque						
Nominal Input Speed n_{1N}	rpm	1,2	4~91	5,000	5,000	4,000	4,000	3,000	3,000	2,000
Max. Input Speed n_{1B}	rpm	1,2	4~91	10,000	10,000	8,000	7,500	4,500	4,500	3,800
Micro Backlash $P0$	arcmin	1	4~10	-	-	≤1	≤1	≤1	≤1	≤1
		2	16~91	-	-	-	≤3	≤3	≤3	≤3
Reduced Backlash $P1$	arcmin	1	4~10	≤3	≤3	≤3	≤3	≤3	≤3	≤3
		2	16~91	≤5	≤5	≤5	≤5	≤5	≤5	≤5
Standard Backlash $P2$	arcmin	1	4~10	≤5	≤5	≤5	≤5	≤5	≤5	≤5
		2	16~91	≤7	≤7	≤7	≤7	≤7	≤7	≤7
Torsional Rigidity	Nm/arcmin	1,2	4~91	3	7	14	25	50	145	225
Max. Bending moment	Nm	1,2	4~91	42.5	125	235	430	1,300	3,064	5,900
Max. Axial Load	N	1,2	4~91	1,080	2,110	2,310	4,800	6,200	5,450	10,600
Input Max. Radial Load F_{2rB} ³	N	1	4~10	165	395	1,300	1,525	2,800	4,500	12,500
		2	16~91	165	165	395	1,300	1,525	2,800	4,500
Input Max. Axial Load F_{2aB} ³	N	1	4~10	580	1,000	1,100	980	2,700	4,700	8,000
		2	16~91	580	580	1,000	1,100	980	2,700	4,700
Service Life	hr	1,2	4~91	30,000*						
Efficiency η	%	1	4~10	≥97%						
		2	16~91	≥94%						
Weight	kg	1	4~10	0.8	1.4	3.4	6.7	13.5	35.0	63.8
		2	16~91	1.1	1.6	4.0	7.3	16.6	36.4	74.7
Operating Temp	°C	1,2	4~91	-10°C~+90°C						
Lubrication		1,2	4~91	synthetic gear grease (NYOGEL 792D)						
Degree of Gearbox Protection		1,2	4~91	IP65						
Mounting Position		1,2	4~91	all directions						
Noise Level ($n_1=3000$ rpm)	dB	1,2	4~91	≤56	≤58	≤60	≤63	≤65	≤67	≤70

Gearbox Inertia

Model No.	Stage	Ratio ¹	ADS047	ADS064	ADS090	ADS110	ADS140	ADS200	ADS255
Mass Moments of Inertia J , $kg \cdot cm^2$	1	4	0.06	0.21	0.87	3.65	10.27	43.05	102.68
		5	0.06	0.21	0.83	3.53	10.17	41.76	99.12
		7	0.06	0.21	0.82	3.47	9.99	41.15	97.41
		10	0.06	0.21	0.81	3.45	9.93	40.97	97.03
	2	16	0.06	0.06	0.21	0.83	3.53	10.17	41.76
		21	0.06	0.06	0.21	0.83	3.53	10.17	41.76
		31	0.06	0.06	0.21	0.83	3.53	10.17	41.76
		61	0.06	0.06	0.21	0.81	3.45	9.93	40.97
		91	0.06	0.06	0.21	0.81	3.45	9.93	40.97

1. Ratio ($i=N_{in}/N_{out}$)

2. $T_{2B} = 60\%$ of T_{2NOT}

3. Applied to the output shaft center @ 100 rpm

* S1 service life 15,000 hrs

ADS Series

Dimensions (1-stage, Ratio $i=4\sim 10$)

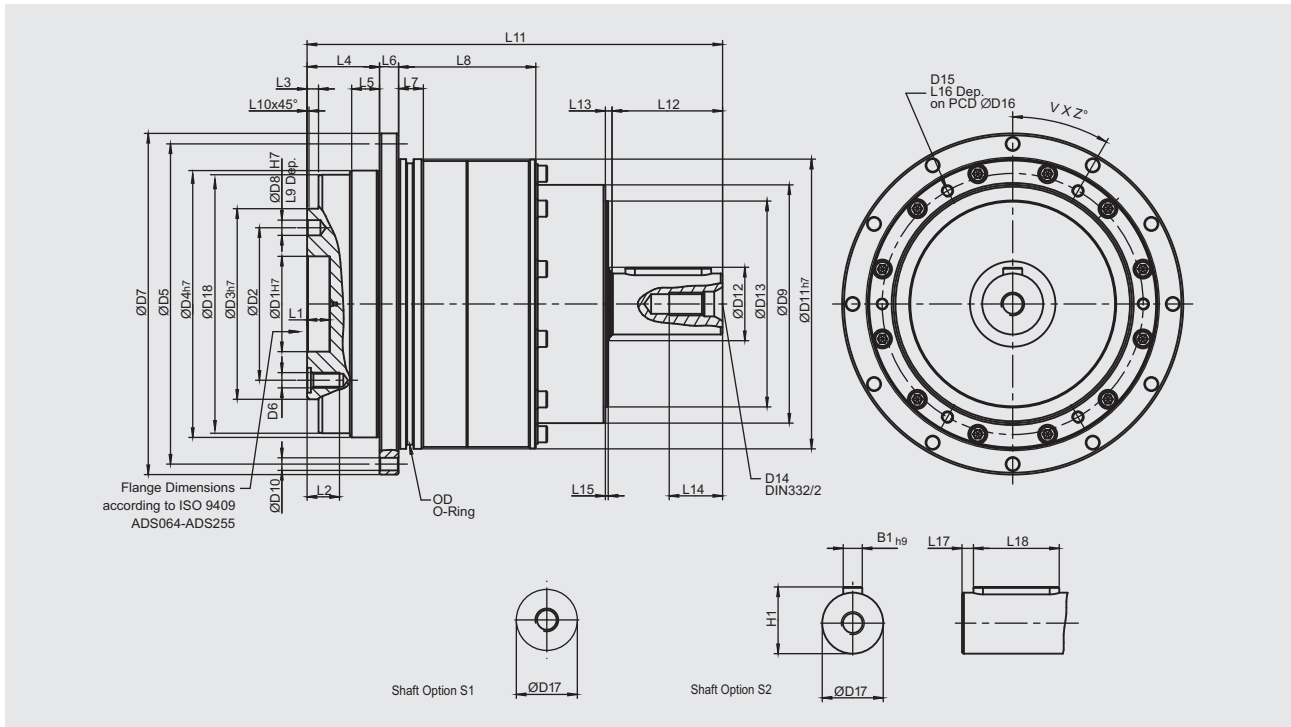

[unit: mm]

Dimension	ADS047	ADS064	ADS090	ADS110	ADS140	ADS200	ADS255
D1 _{H7}	12	20	31.5	40	50	80	100
D2	20	31.5	50	63	80	125	140
D3 _{H7}	28	40	63	80	100	160	180
D4 _{H7}	47	64	90	110	140	200	255
D5	67	79	109	135	168	233	280
D6	4 x M3 x 0.5P	7 x M5 x 0.8P	7 x M6 x 1P	11 x M6 x 1P	11 x M8 x 1.25P	11 x M10 x 1.5P	12 x M16 x 2P
D7	72	86	118	145	179	247	300
D8 _{H7}	3	5	6	6	8	10	12
D9	43	55	78	100	125	175	210
D10	8 x 3.4	8 x 4.5	8 x 5.5	8 x 5.5	12 x 6.6	12 x 9	16 x 13.5
D11 _{H7}	60	70	95	120	152	212	255
D12	31	22	22	30	40	75	95
D13	37	50	62	82	108	145	172
D14	M4 x 0.7P	M4 x 0.7P	M5 x 0.8P	M8 x 1.25P	M12 x 1.75P	M16 x 2P	M20 x 2.5P
D15	M3 x 0.5P	M3 x 0.5P	M4 x 0.7P	M5 x 0.8P	M6 x 1P	M8 x 1.25P	M8 x 1.25P
D16	51.5	61.5	84	107	137	193	235
D17 _{K6}	11	14	16	22	32	40	55
D18	46.2	63.2	89.2	109.2	139.2	199.2	254.2
L1	4	8	12	12	12	16	20
L2	6.5	8	13.5	13.5	17	22.5	30.5
L3	3	3	6	6	6	8	12
L4	19.5	19.5	30	29	38	50	66
L5	7	7	10	10	14.6	15	20
L6	4	4	7	8	10	12	18
L7	5	7.7	8	10	12	15	20
L8	32.5	43.5	47	62	72	89.5	112
L9	4	6	7	7	7	10	10
L10	0.5	0.5	1	1	1	1	1
L11	89.5	110.5	138.5	170	218	296	372.5
L12	18	22	28	36	58	82	115
L13	2.5	2.5	3.5	3.5	3.5	4.5	4.5
L14	10	10	12.5	19	28	36	42
L15	1.5	1.5	1.5	1.5	1.5	1.5	1.5
L16	5.5	5.5	7	9	11	14	14
L17	2	2	3	3	6	6	7
L18	14	18	22	28	45	70	90
B1 _{H9}	4	5	5	6	10	12	16
H1	12.5	16	18	24.5	35	43	59
OD	56 x 2	66 x 2	90 x 3	110 x 3	145 x 3	200 x 5	238 x 5
V	4	4	4	4	6	6	6
Z	45	45	45	45	30	30	30

ADS Series

Dimensions (2-stage, Ratio $i=16\sim 91$)

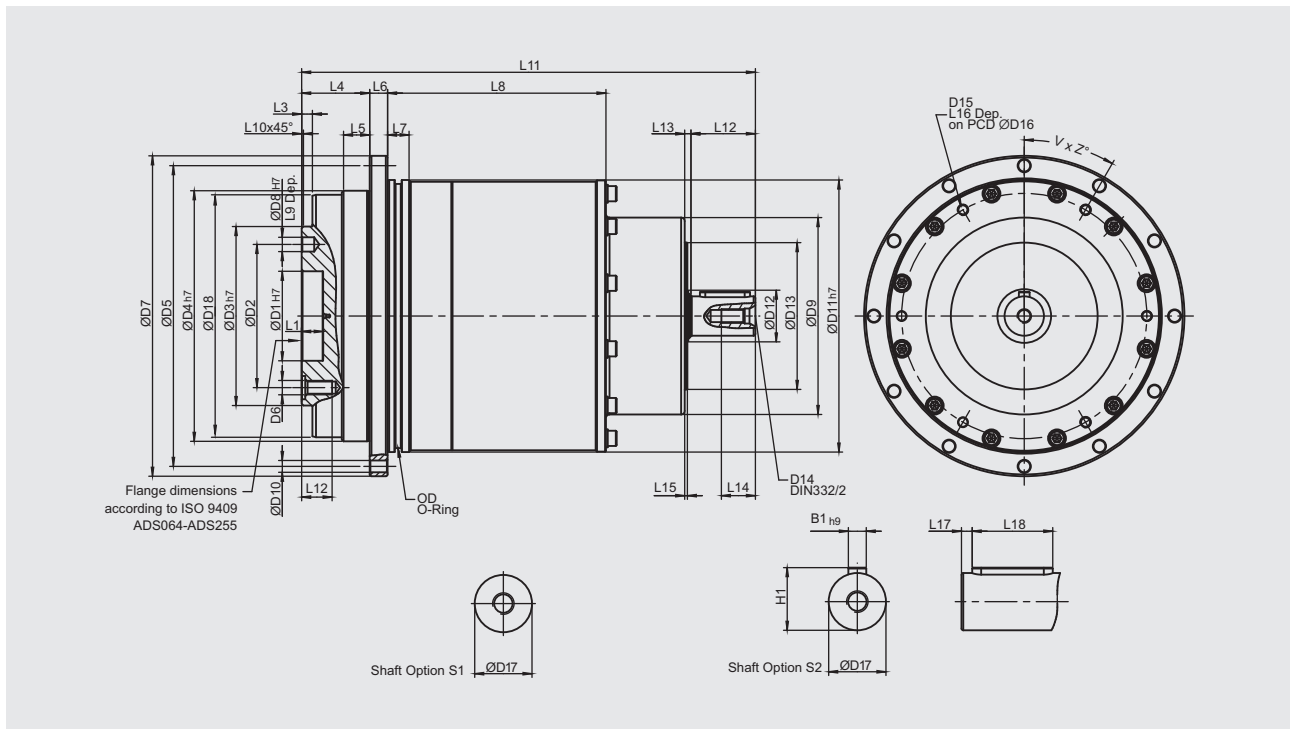

[unit: mm]

Dimension	ADS047	ADS064	ADS090	ADS110	ADS140	ADS200	ADS255
D1 _{H7}	12	20	31.5	40	50	80	100
D2	20	31.5	50	63	80	125	140
D3 _{H7}	28	40	63	80	100	160	180
D4 _{H7}	47	64	90	110	140	200	255
D5	67	79	109	135	168	233	280
D6	4 x M3 x 0.5P	7 x M5 x 0.8P	7 x M6 x 1P	11 x M6 x 1P	11 x M8 x 1.25P	11 x M10 x 1.5P	12 x M16 x 2P
D7	72	86	118	145	179	247	300
D8 _{H7}	3	5	6	6	8	10	12
D9	43	48	68	86	110	132	182
D10	8 x 3.4	8 x 4.5	8 x 5.5	8 x 5.5	12 x 6.6	12 x 9	16 x 13.5
D11 _{H7}	60	70	95	120	152	212	255
D12	22	22	22	22	30	40	75
D13	37	37	50	62	82	108	145
D14	M4 x 0.7P	M4 x 0.7P	M4 x 0.7P	M5 x 0.8P	M8 x 1.25P	M12 x 1.75P	M16 x 2P
D15	M3 x 0.5P	M3 x 0.5P	M4 x 0.7P	M5 x 0.8P	M6 x 1P	M8 x 1.25P	M10 x 1.5P
D16	51.5	61.5	84	107	137	193	235
D17 _{K6}	11	11	14	16	22	32	40
D18	46.2	63.2	89.2	109.2	139.2	199.2	254.2
L1	4	8	12	12	12	16	20
L2	6.5	8	13.5	13.5	17	22.5	30.5
L3	3	3	6	6	6	8	12
L4	19.5	19.5	30	29	38	50	66
L5	7	7	10	10	14.6	15	20
L6	4	4	7	8	10	12	18
L7	5	7.7	8	10	12	15	20
L8	62.5	63.5	67	82	122	79.5	177
L9	4	6	7	7	7	10	10
L10	0.5	0.5	1	1	1	1	1
L11	119.5	125.5	158.5	188	253.5	314.5	419.5
L12	18	18	22	28	36	58	82
L13	2.5	2.5	2.5	3.5	3.5	3.5	4.5
L14	10	10	10	12.5	19	28	36
L15	1.5	1.5	1.5	1.5	1.5	1.5	1.5
L16	5.5	5.5	7	9	11	14	18
L17	2	2	2	3	3	6	6
L18	14	14	18	22	28	45	70
B1 _{h9}	4	4	5	5	6	10	12
H1	12.5	12.5	16	18	24.5	35	43
OD	56 x 2	66 x 2	90 x 3	110 x 3	145 x 3	200 x 5	238 x 5
V	4	4	4	4	6	6	6
Z	45	45	45	45	30	30	30

Output Dimensions

**AD 047
ADR 047
ADS 047**

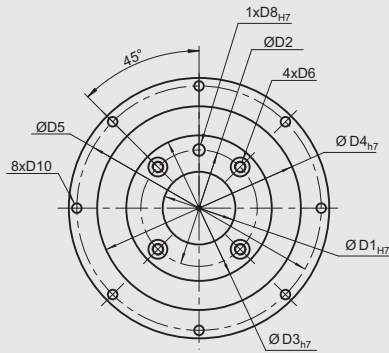

**AD 064 / AD 090
ADR 064 / ADR 090
ADS 064 / ADS 090**

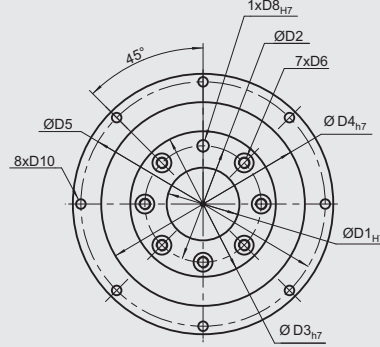

**AD 110
ADR 110
ADS 110**

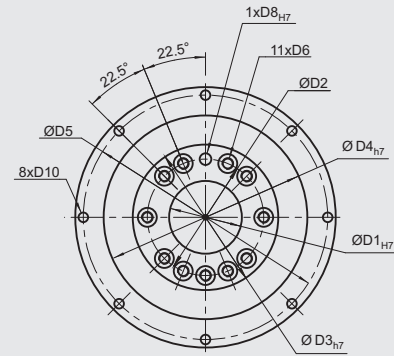

**AD 140 / AD 200
ADR 140 / ADR 200
ADS 140 / ADS 200**

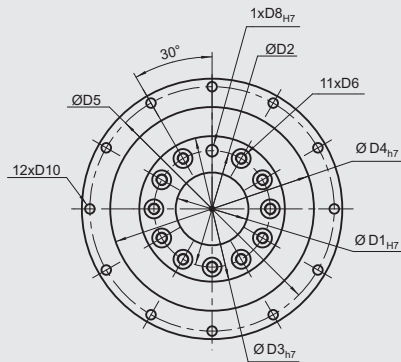

**AD 255
ADR 255
ADS 255**

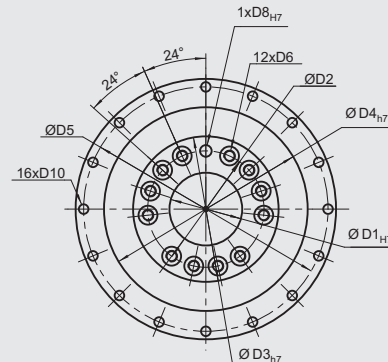

[unit: mm]

Dimension	AD047	AD064	AD090	AD110	AD140	AD200	AD255
	ADR047	ADR064	ADR090	ADR110	ADR140	ADR200	ADR255
	ADS047	ADS064	ADS090	ADS110	ADS140	ADS200	ADS255
D1 _{H7}	12	20	31.5	40	50	80	100
D2	20	31.5	50	63	80	125	140
D3 _{H7}	28	40	63	80	100	160	180
D4 _{H7}	47	64	90	110	140	200	255
D5	67	79	109	135	168	233	280
D6	M3 x 0.5P	M5 x 0.8P	M6 x 1P	M6 x 1P	M8 x 1.25P	M10 x 1.5P	M16 x 2P
D8 _{H7}	3	5	6	6	8	10	12
D10	3.4	4.5	5.5	5.5	6.6	9	13.5

Permitted Radial and Axial Loads on Input Shaft of the ADS Gearbox

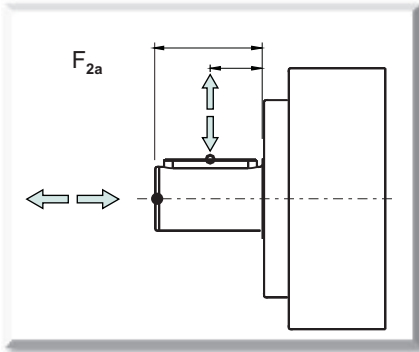

The permitted radial and axial loads on input shaft of the gearbox depend on the design of the gearbox supporting bearings. APEX use deep groove double roll ball bearing design. It can take heavy load from both axes.

F_{2r} Radial Load
 F_{2a} Axial Load

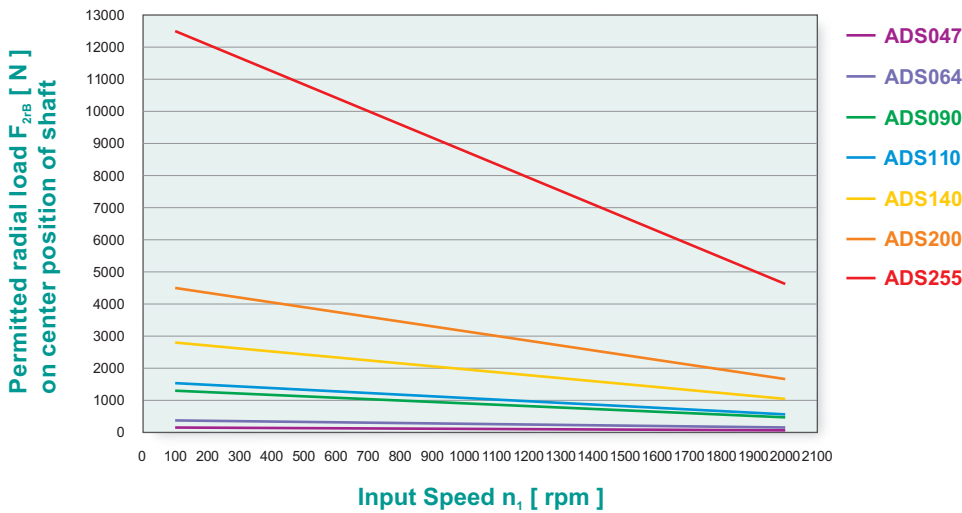

If radial force F_{2r} exert on the center of the input shaft $X=1/2 \times L$. Under various operating condition the lifetime is over 30,000 hours*. The permitted radial load is given on left diagram.

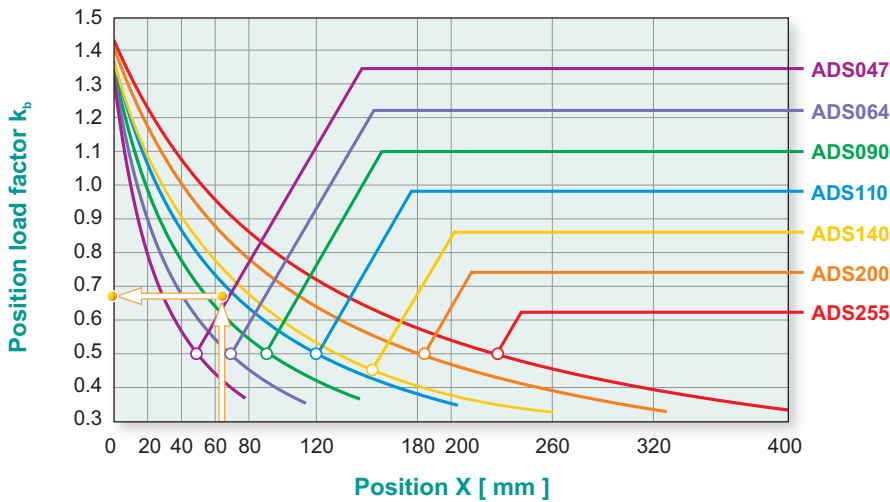

* Continuous running reduces service life by 50%

If radial force F_{2r} not exert on the center of the input shaft $X < 1/2 \times L$ or $X > 1/2 \times L$. The permitted radial and axial load can be calculated by the position load factor k_b on the left diagram.

Ordering Code

AD Series

AD047

–

010

–

P1

/

MOTOR

Gearbox Size:

AD047, AD064, AD090
AD110, AD140, AD200, AD255

Backlash:

P0: Micro Backlash
P1: Reduced Backlash
P2: Standard Backlash

Ratio:

1 Stage: 4, 5, 7, 10
2 Stage: 20, 25, 35, 40, 50, 70, 100
16, 21, 31, 61, 91

Motor Designation:

Manufacturer Type
And Model

Ordering Example: AD047-010-P1 / SIEMENS 1FT6 041-4AF71

ADR Series

ADR047

–

010

–

P1

/

MOTOR

Gearbox Size:

ADR047, ADR064, ADR090
ADR110, ADR140, ADR200, ADR255

Backlash:

P0: Micro Backlash
P1: Reduced Backlash
P2: Standard Backlash

Ratio:

1 Stage: 4, 5, 7, 10, 14, 20
2 Stage: 20, 25, 35, 40, 50, 70, 100, 140, 200

Motor Designation:

Manufacturer Type
And Model

Ordering Example: ADR047-010-P1 / SIEMENS 1FT5 034-OAK71

ADS Series

ADS047

–

010

–

S1

–

P1

Gearbox Size:

ADS047, ADS064, ADS090
ADS110, ADS140, ADS200, ADS255

Shaft Option:

S1: Smooth Input Shaft
S2: Input Shaft with Key

Ratio:

1 Stage: 4, 5, 7, 10
2 Stages: 16, 21, 31, 61, 91

Backlash:

P0: Micro Backlash
P1: Reduced Backlash
P2: Standard Backlash

Ordering Example: ADS090-010-S1-P1

■ Please visit our website for newest update data.



APEX DYNAMICS, INC.

No.10, Keyuan 3rd Rd., Situn District, Taichung City 407, Taiwan (R.O.C.)

Tel: 886 4 23550219 / Fax: 886 4 23550218

E-mail: sales@apexdyna.com / Website: www.apexdyna.com

APEX-2009-10-AD / ADR / ADS-3.1V



